



Dial device

Help



Creating connection



With worldwide TCP/IP communication!

OCM Pro CF

High accurate Flow Measurement in Channels, part filled and full Pipes as well as in Flumes and Surface Water Bodies

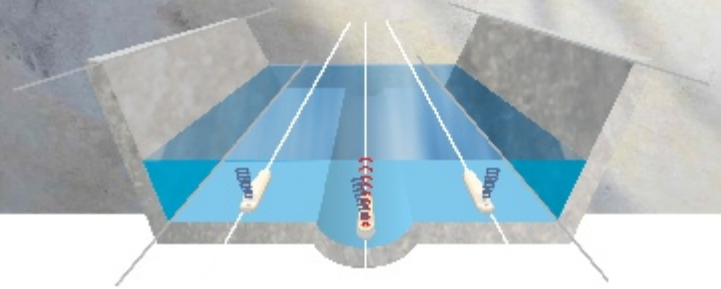

New in the Flow Measurement Area

NIVUS flow measurement technology stands for innovation and high accuracy.

The OCM Pro CF is a permanent measurement system for continuous flow measurement, flow control and storage of recorded data in a range from slight to heavily polluted media of various consistencies.

It is designed for use in part filled and full pipes, channels and flumes with many different shapes and dimensions.

The OCM Pro CF is equipped with fast processors and offers online access via the Internet. This ensures more versatile, more reliable and more economic operation.



Overview on Transmitter Details

- very high accuracy
- measures and indicates the real flow velocity profile
- spatial allocation of measured single velocities
- cross correlation with digital pattern detection
- absolutely stable zero point and drift-free
- no electrodes, no conductivity required
- measures in all channels, part filled and full pipes and flumes
- measures in heavily polluted and abrasive media
- no external calibration required
- suitable even for very difficult applications
- easy installation without additional constructions
- Ex approval for zone 1 as ATEX
- very easy parameter setting in multilingual dialog mode
- large, back-lit graphic display
- stores complete measurement data on Compact Flash card
- worldwide TCP/IP communication
- online connection/data transmission and remote maintenance via Internet



Lift-up mechanism for inspection purposes or for sensor removal under operational conditions

Sensors - high accuracy and universal use

A complete OCM Pro CF measurement place consists of a transmitter and appropriate active sensors. There are flow velocity sensors with and without integrated flow level measurement available as well as air-ultrasonic flow level sensors for direct connection to OCM Pro CF. Various constructions can be used depending on the kind of application. You can select from wedge sensors for installation in channels and open flumes or pipe sensors for installation in steel, concrete and plastic pipes.

Your benefits

- no modifications or additional constructions at place of installation
- triple redundant level measurement (air-ultrasound, water-ultrasound, hydrostatic)
- measurement dynamics between 5 mm/s and 6 m/s
- measures in both flow directions
- highly medium-resistant standard sensors (PPO, PEEK, 1.4571, Hastelloy C276)
- sensors resistant to chemicals for highest demands
- cables can be extended without any problems
- Ex approval zone 1 as ATEX
- protection rating IP 68



Air-ultrasonic sensor
for level measurement,
installation on channel crown

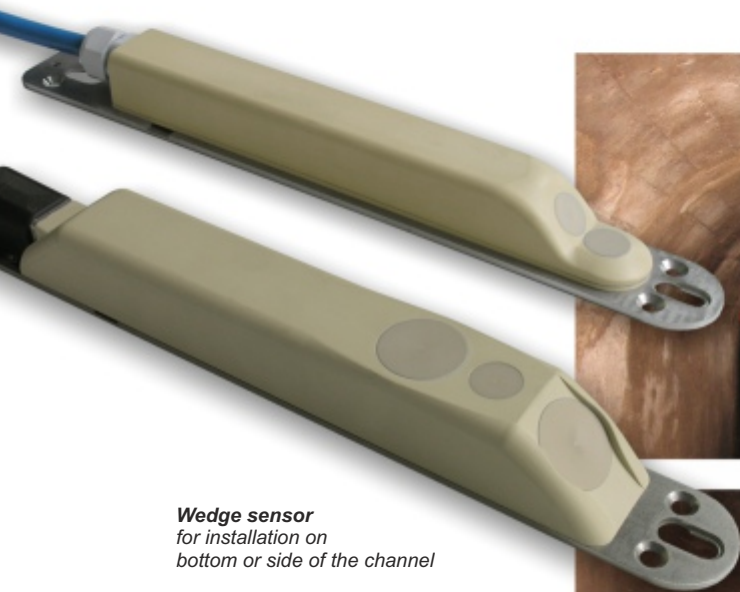

Wedge sensor
for installation on
bottom or side of the channel

Types:

- v-measurement only
- combined v-measurement and h-measurement (ultrasound)
- combined v-measurement and h-measurement (pressure)
- combined v-measurement and h-measurement (ultrasound and pressure)



Pipe sensor
for installation in pipes and in
NIVUS Pipe Profiler

Types:

- v-measurement only
- combined v-measurement and h-measurement (Ultrasonic)



Successful in use anywhere

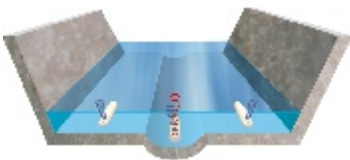
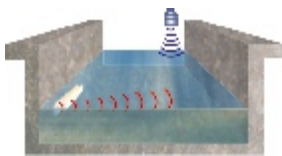

Flow measurement in rectangular channel of a sewage treatment plant

Due to heavy vorticity 3 sensors have been installed. Since initial start-up in December 2001 the measurement runs without interruption.

Standard sensor installed on a wedge

Due to heavy sedimentation in the channel it was necessary to install this special construction. The measurement operates reliably since initial installation.

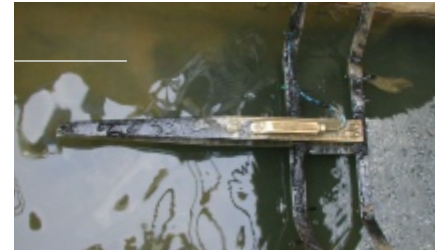

Measurement in a full filled recirculation line

A full filled recirculation pipe is on the ground of a constantly filled denitrification tank. The measurement in the filled tank was desired to be accessible at any time. The flow velocity sensor has been installed in a guiding tube with a length of 8 m.

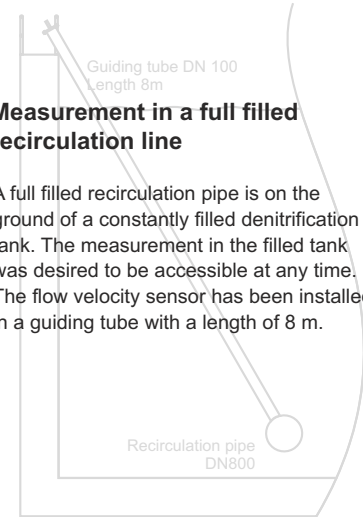

Typical areas of use for OCM Pro CF

- wastewater treatment plants: inlet, discharge, inlet to aeration tanks, return sludge, recirculation, surplus sludge, discharge from digester and flocculant dosing point
- permanent measurements on storm water basin, storm water retention basin, storm water sedimentation tank
- direct discharger control, investigation of extraneous water or leakage
- industrial wastewater networks
- industrial flow measurements
- irrigation systems
- inlets and outlets conducting cooling water or circulation systems
- sluice stages in rivers
- hydroelectric and thermic power plants
- measurement campaigns in channel networks
- MCERTS applications
- and many more

NIVUS - the perfect Solution for each Application

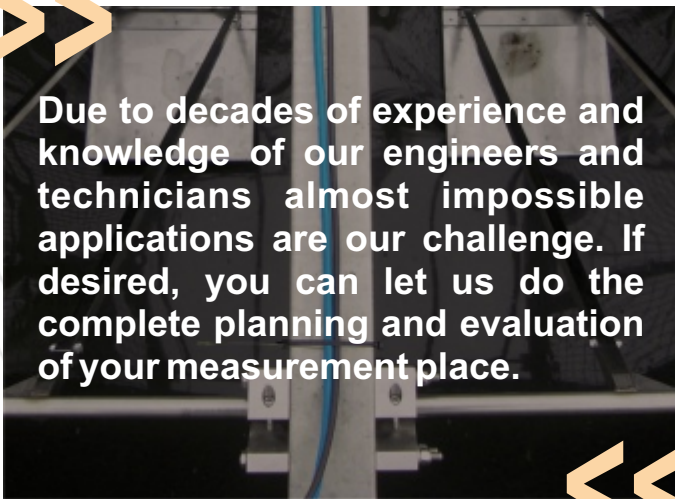
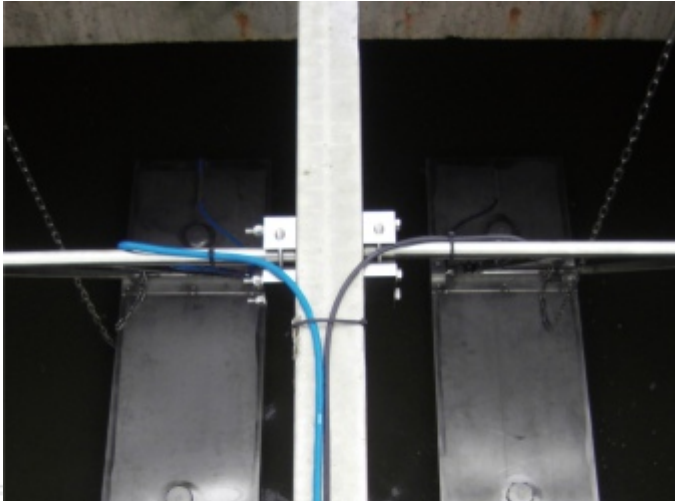

Due to decades of experience and knowledge of our engineers and technicians almost impossible applications are our challenge. If desired, you can let us do the complete planning and evaluation of your measurement place.

Exemplified measurement tasks:

A flow measurement which is insensitive to soiling and sedimentation without the need to be cleaned frequently. The measurements shown in the examples have been developed in order to reliably and accurately detect flow levels considering fluctuations of sludge layers.

In this case OCM measurements with combi wedge sensors have been used which e.g. were placed on the water surface by using vertically movable "floats".

The prevailing water level down to the

sludge surface is going to be detected by using the ultrasonic transit time method.

The flow velocity sensor thanks to the cross correlation provides the accurate flow velocity profile and hence an accurate image of the flow conditions and the flow velocity in the channel.

You need an individual solution for your measurement problem or you are interested in more application examples and references?

Just talk to us.

How the OCM Pro CF measures

Flow cannot be measured directly. Multiple factors are required to detect the flow Q : average flow velocity and the flow cross section. This leads to the general formula below:

$$Q = v_{(average)} \cdot A$$

The flow cross section A is investigated by continuously measuring the filling level considering the channel shape. The flow cross section and hence the flow changes as soon as the level changes.

The flow velocity is detected via the velocity of the particles. Most media contain a certain load of dirt particles or gas bubbles which move in the same velocity as the liquid. The particle velocity is measured by using ultrasound. The flow changes as soon as the velocity changes.

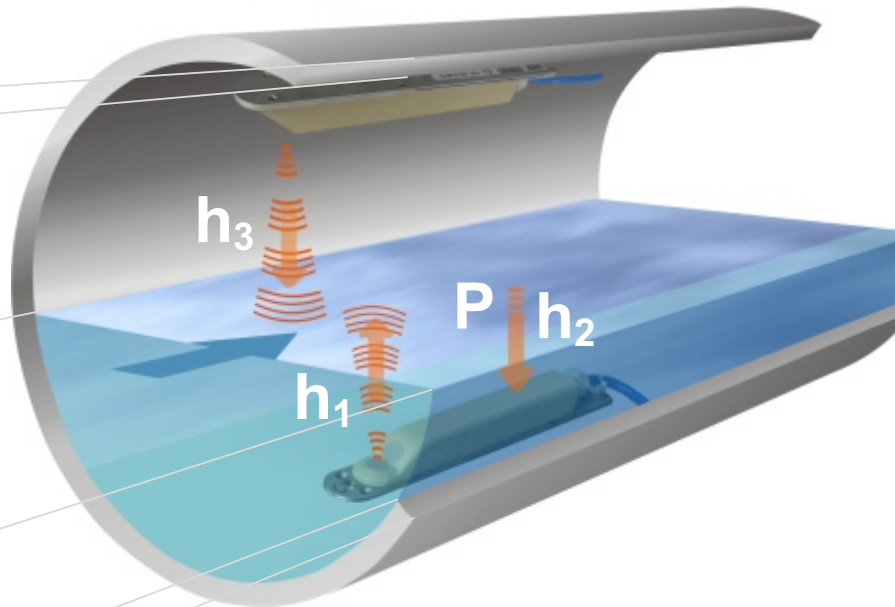

Level Measurement (h)

Accurate flow measurement requires precise and reliable level detection under all hydraulic conditions. The development of a level measurement system with multiple redundancy is a result of our many years of experience.

Combining hydrostatic measurement, water-ultrasound and air-ultrasound provides solutions for all measurement tasks. External 4- 20 mA level sensors such as NivuCompact or NivuBar Plus can be connected additionally.

Based on the ultrasonic echo sounding principle the flow height (water level) is either going to be measured from the bottom up [h_1] in the liquid or from top down [h_3] using air-ultrasound.

The interface between water and air (water surface) will be detected in both cases and the sound transit time between sensor and water surface is going to be measured.

Foam or any other substances on the water surface do not affect the measurement result.

In conditions where liquids are strongly absorbant or the combi sensor is off-set it is possible to measure the fill level by using an optionally available built-in hydrostatic measurement [h_2].



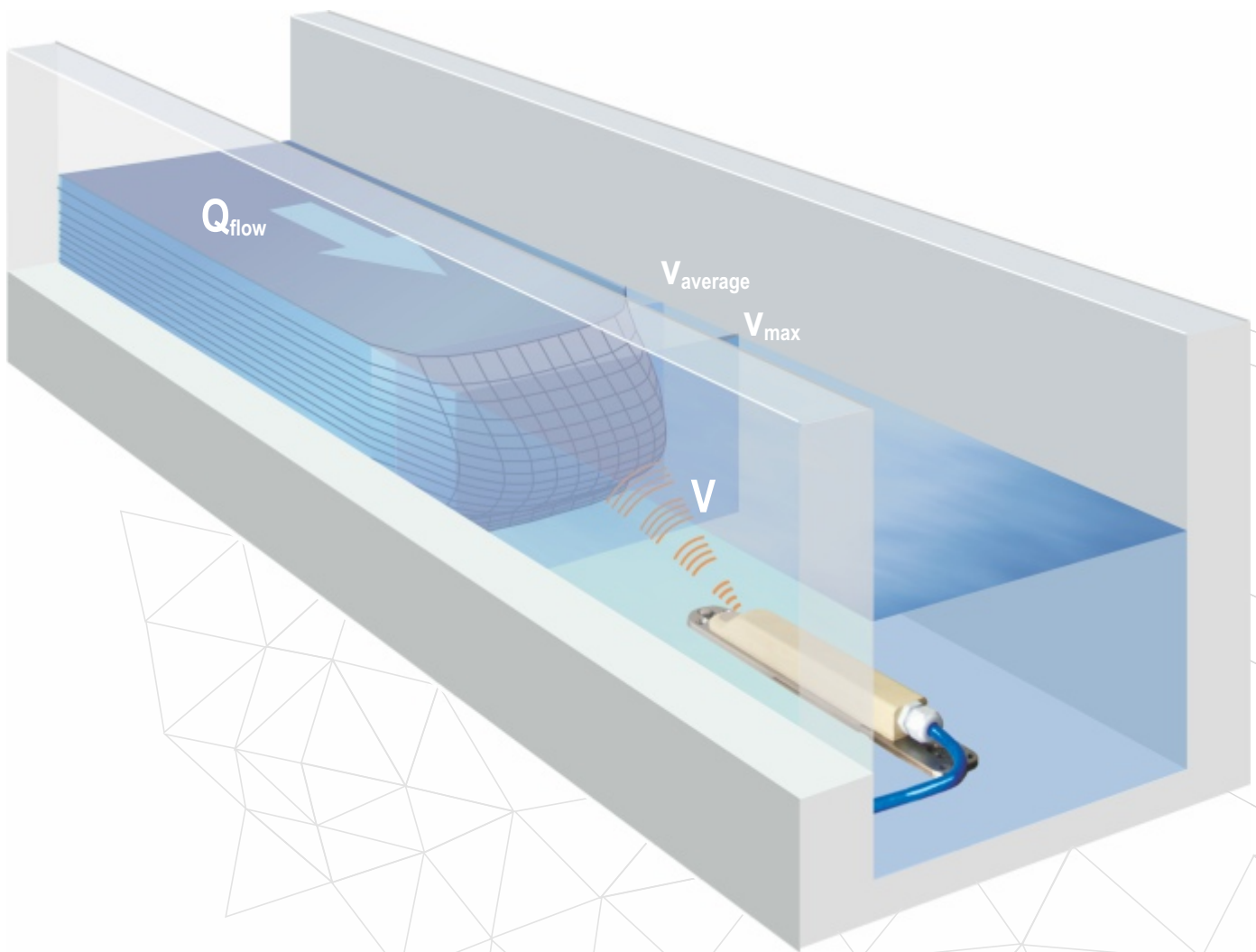

Flow velocity measurement (v)

The measurement method used for flow velocity investigation is based on the principle of ultrasonic reflection. One of the most modern and most efficient methods for the detection and calculation of the flow velocity is the correlation method (interrelation between two similar image patterns) by NIVUS.

A prerequisite to use this method are reflecting particles (minerals or gas bubbles) contained in the liquid.

The measured velocities then can exactly be allocated spatially and indicated as well.



The newly developed NIVUS-COSP technology turns the velocity measurement into a grid measurement according to VDI/VDE. Using an OCM Pro plus 3 sensors creates a measurement grid with 48 spatially allocated single velocities resulting in a high accurate flow measurement.



... using cross correlation

Existing reflectors (particles, minerals or gas bubbles) are scanned using an ultrasonic impulse with a defined angle. The resulting echoes are saved subsequently as images or echo patterns.

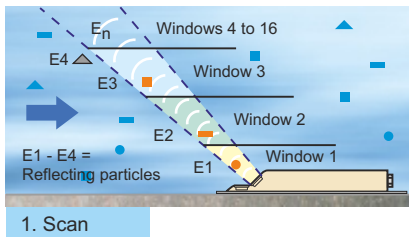

A few milliseconds later a second scan follows. The resulting echo patterns are saved as well.

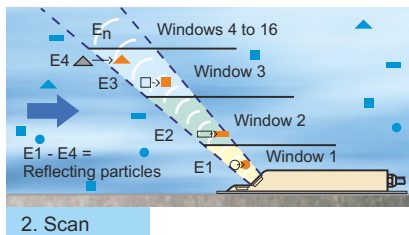

By correlating the saved signals, the positions of unambiguously identifiable reflectors can be identified. Since the reflectors have moved with the liquid, they can be identified at varying positions in the images.

Overlay of image patterns

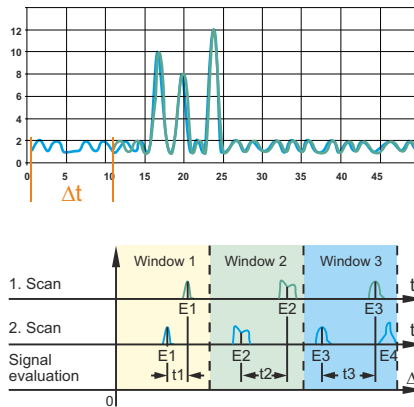

Considering beam angle and the impulse repeat rate it is possible to directly compute the particle velocity and hence the liquid flow velocity from the temporal shift of the reflectors. This allows to obtain high accurate readings without performing additional calibration measurements.

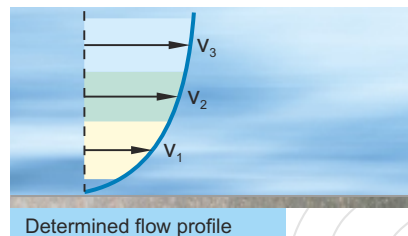

Your benefits

- Highest possible accuracy, since all particles are detected over the entire measurement beam
- Stable readings
- No calibration required
- Direct indication of flow profiles
- Measurement even in large profiles
- For use with all flow cross sections in full or partial filling

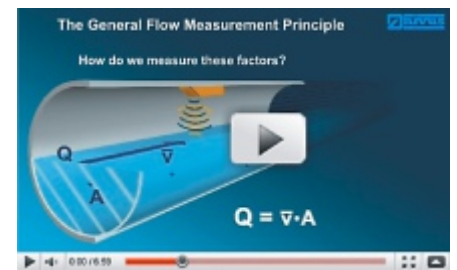

The NIVUS movie "The principle of flow measurement" thoroughly explains the flow velocity measurement using cross correlation. Just watch on www.nivus.com



Flow profile indication on the display.

RUN PAR I/O CAL EXTRA
sensors
v-sensor

h[m]	v[m/s]
11	0.032 0.473
21	0.037 0.470
31	0.042 0.480
41	0.048 0.484
51	0.055 0.488
61	0.062 0.494
71	0.072 0.483
81	0.082 0.481

Measurement values can be directly read on the display.

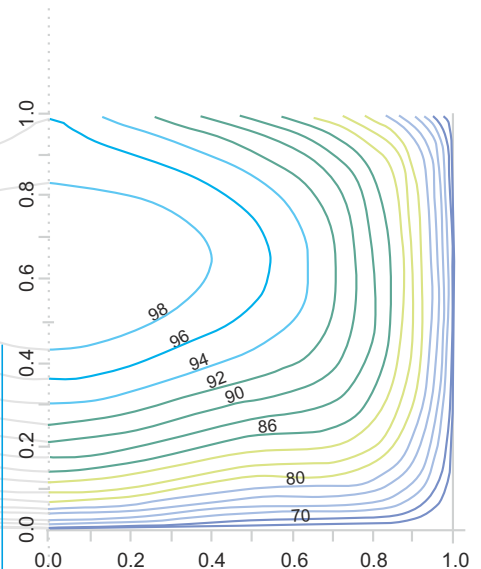

On-site from anywhere

- complies with worldwide interface standard using TCP/IP Ethernet
- integrated web server
- online access via Internet browser without the need to install additional software
- Permanent online via GPRS
- integrated data logger for high data reliability
- saved data can be read out via Internet at any time
- quick and comprehensive remote diagnostics of entire measurement place (online service)

The OCM Pro CF offers innovative communication options for remote maintenance, remote diagnosis and data transfer as standard. This is how to interconnect the latest measurement technology worldwide at any time.

Using its integrated web server the OCM Pro CF provides a dedicated website using TCP/IP. Besides being used within internal networks this option allows the user to connect the unit to the world wide web. Due to the specially designed operating system the unit is absolutely resistant to virus attacks.

Remote control options enable to access any functions which are available on site.

Remote control options enable to access any functions which are available on site. The screen indicated is equal to the on-site display.

Data can be transferred simply by one mouse click. Internet connection enables the user to maintain, control and analyse several measurement places from anywhere in the world simultaneously.

more on www.nivus.com.

- Measurement online
- D2W - Device to Web Internet portal



Log in using password or via demo account test on www.nivus.com

D2W Internet portal - data management with many options

Specifications Transmitter

Wall mount enclosure, Type W0

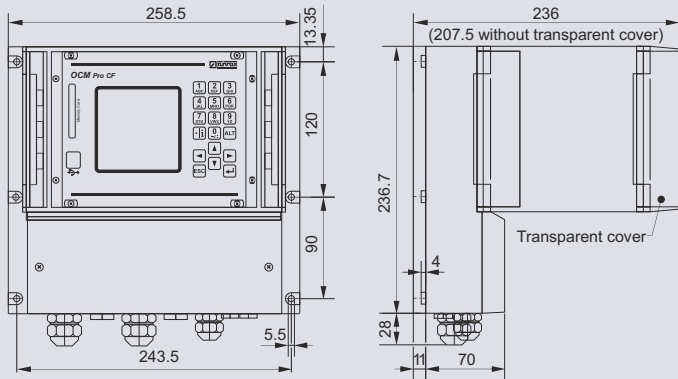

Panel mount enclosure, Type F0

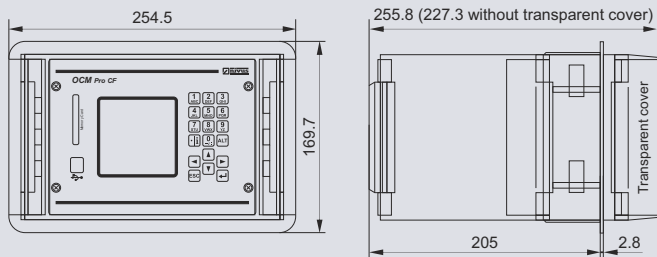

Dimensions in mm

Supply power	100 to 240 V AC, +10 % /-15 %, 47 to 63 Hz or 9 to 36 V
Power consumption	AC: 31 VA; DC: 34 W (14 W typical)
Wall mount enclosure	material: Polycarbonate / weight approx. 3400 g protection: IP65
Panel mount enclosure	material: Polycarbonate / weight approx. 2900 g protection: IP54 (front side) IP20 (reverse side)
Ex Approval	II(2)G [Ex ib] II B
Operating temperature	-20°C to +50°C
Storing temperature	-30°C to +70°C
Max. Humidity	80 %, non-condensing
Display	back-lit graphic display, 128 x 128 Pixel
Operation	18 keys, menus in German, English, French, Italian, Spanish, Polish, Danish, Swedish
Inputs	1 x 4 - 20 mA for external level, 1 x RxTx-Bus for NIVUS air-ultrasonic sensor Type OCL, up to 4 x 0/4 - 20 mA with 12 bit resolution for external level, external setpoints and data storage up to 4 digital inputs, up to 3 velocity sensors Type POA or CS2
Outputs	up to 4 x 0/4 - 20 mA, load 500 Ohm, 12 bit resolution, up to 5 Relays/SPDT
Data memory	Compact Flash Card up to 128 MB
Storage cycle	1 to 60 minutes
Data transmission	Compact Flash Card, Modbus TCP via Ethernet with integrated web server; connection via networks (LAN / WAN, Internet), Internet via Ethernet or optional via internal ISDN, GPRS or analog modem

Specifications Sensors

Water-Ultrasonic Combi Sensors, Type POA

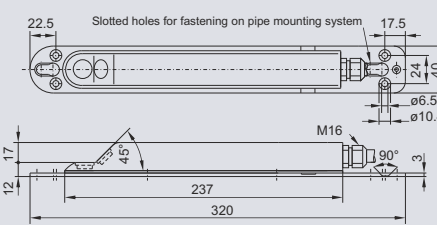

Vector Profiler, Type CS2

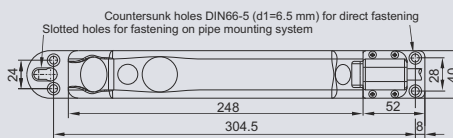
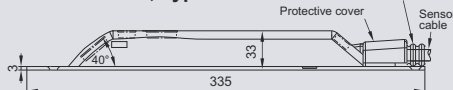

Air-Ultrasonic Level Sensor, Type OCL

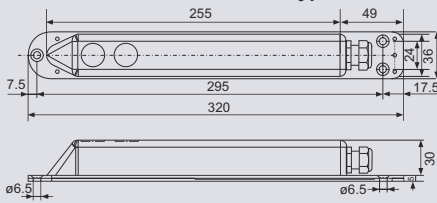

Dimensions in mm

Pipe Sensors Type POA

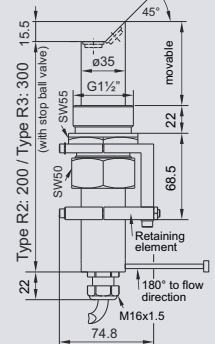

Type CS2

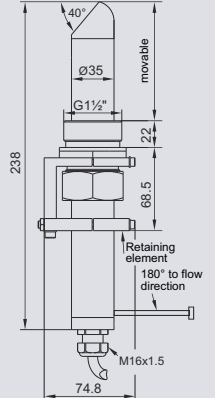

Measurement principle	<ul style="list-style-type: none"> • cross correlation with digital pattern detection for flow velocity measurement • ultrasonic transit time for level measurement • piezoresistive pressure meas. for level measurement
Meas. range (v)	-100 cm/s to +600 cm/s
Meas. range (h)	pressure 350 cm, ultrasound internal up to 500 cm
Meas. frequency	1 MHz
Protection	IP68
Ex Approval	II 2 G Ex ib IIB T4
Operating temp.	-20°C to +50°C (-20°C to +40°C in Ex Zone 1)
Storing temperature	-30°C to +70°C
Meas. uncertainty	deviation less than 1 %
Operating pressure	max. 4 bar (combi sensor w. pressure cell max. 1 bar)
Cable length	up to 100 m, other lengths on request
Sensor types	POA or CS2 (for levels of several meters): flow velocity using cross correlation or flow velocity and level, temperature measurement level measurement using water-ultrasound (optional) level measurement using pressure (optional) OCL : level measurement using ultrasound
Constructions	wedge sensor for installation on channel bottom pipe sensor incl. retaining element for installation in pipes using a nozzle
Materials	Polyurethane, stainless steel 1.4571, PPO GF30, PA (wedge sensor), PTFE (pipe sensor), Option: sensor made of PEEK resistant to chemicals, Hastelloy mounting plate; Titanium mounting plate; FEP-coated cable

The specifications above are extracts from the complete documentation. You can find the complete specifications in the instruction manual.

NIVUS GmbH
Head office
 Im Tael 2
 75031 Eppingen, Germany
 Phone: +49 (0)7262 9191 0
 Fax: +49 (0)7262 9191 999
 E-mail: info@nivus.com
 Internet: www.nivus.com

NIVUS AG
 8750 Glarus, Switzerland
 Phone: +41 (0)55 6452066
 E-mail: swiss@nivus.com

NIVUS Austria
 3382 Loosdorf, Austria
 Phone: +43 (0)2754 567 63 21
 E-mail: austria@nivus.com

NIVUS Sp. z o.o.
 81-212 Gdynia, Poland
 Phone: +48 (0)58 7602015
 E-mail: poland@nivus.com

NIVUS France
 67770 Sessenheim, France
 Phone: +33 (0)3 880716 96
 E-mail: france@nivus.com

NIVUS Ltd. (UK)
 Leamington Spa, Warwickshire
 Phone: +44 (0)1926 632470
 E-mail: info@nivus.com

NIVUS Ltd. (UK)
 Eaglescliffe, Cleveland
 Phone: +44 (0)1642 659294
 E-mail: info@nivus.com

NIVUS Middle East (FZE)
 Sharjah Free Zone, UAE
 Phone: +971 6 55 78 224
 Middle-East@nivus.com

NIVUS Korea Co. Ltd.
 Gyeonggi-Do 415-843
 Phone: +82 31 999 5920
 E-mail: korea@nivus.com